

**RYERSON UNIVERSITY
DEPARTMENT OF COMPUTER SCIENCE**

**CPS 420
MIDTERM
WINTER 2023**

INSTRUCTIONS

- This exam is 120 minutes long.
- This exam is out of 50 and is worth 25% of the course mark.
- This is a closed book exam. However, one double-sided letter-sized crib sheet is allowed.
- This exam is double-sided and has 10 pages including this front page. The last 3 pages are blank. Therefore there are 6 pages of questions: pages 2 to 7 inclusive.
- Please answer all questions directly on this exam. If you need extra space to finish answering questions, please do so on pages 8, 9, 10 and indicate very clearly on the original page of each question on which page the rest of your answer can be found.

PART A – GRAPH THEORY – 25 MARKS

1. River Crossing (8 marks)

- Two small robots and two large robots are on the left bank of a river and need to cross to the right bank using a boat. This boat can only carry one large robot, one small robot, or two small robots: two large robots do not fit on the boat. The boat can only move if there is a robot in it.
- Draw a state diagram (directed graph) to figure out how these four robots can cross the river on the boat. All possible situations and crossing actions have to be represented in the graph. Each state (vertex in the graph) only appears once and must be labeled with the following short hand representing the position of the boat and all the robots on the banks of the river: s for one small robot; L for one large robot; B for the boat, and | for the river. Each edge label describes who is crossing the river in the boat.
- The initial vertex representing the starting state where all robots and the boat are on left bank has been provided:



2. Euler and Hamiltonian Circuits (6 marks)

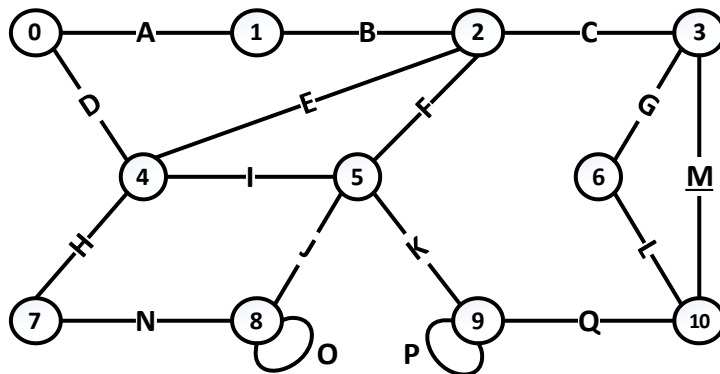

a) Give a **Euler** circuit starting at vertex 0 for the graph above, **or** explain why this graph does not have a **Euler** circuit.

b) Give a **Hamiltonian** circuit starting at vertex 0 for the graph above, **or** explain why this graph does not have a **Hamiltonian** circuit.

3. Minimum Spanning Tree (5 marks)

In the right box below, draw a minimum spanning tree for the graph in the left box.

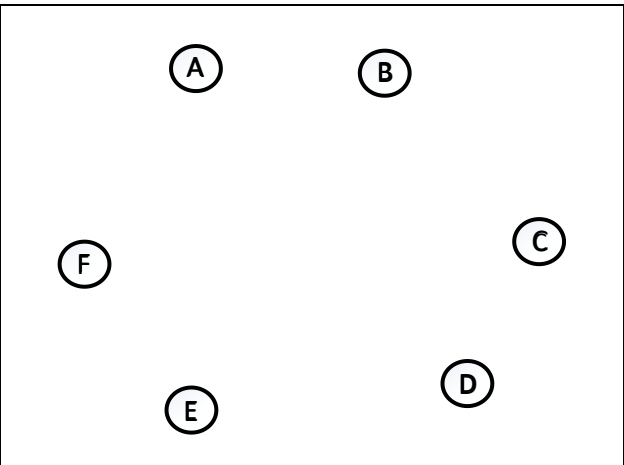
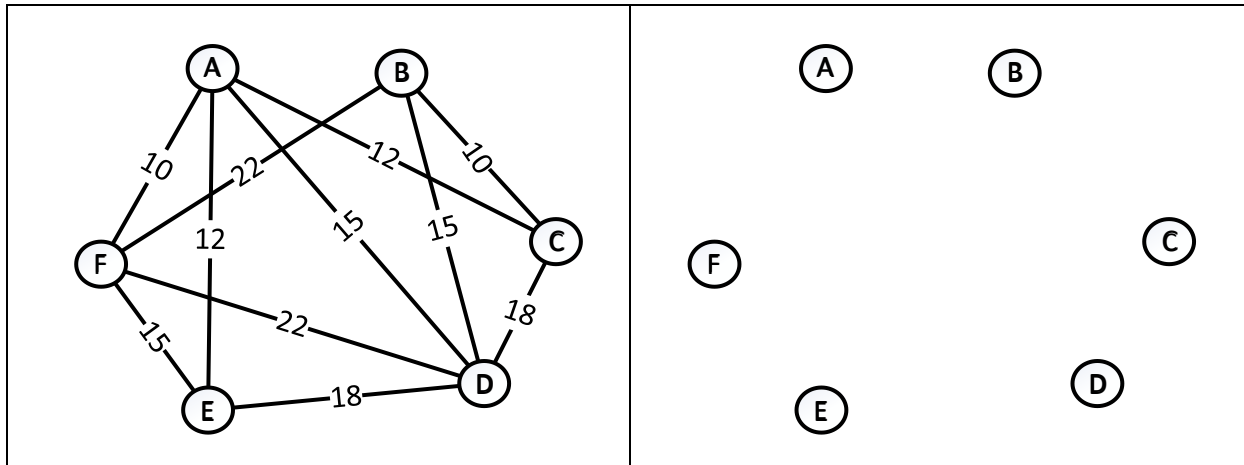

4. Isomorphic Graphs (6 marks)

The two graphs G and H below are isomorphic:

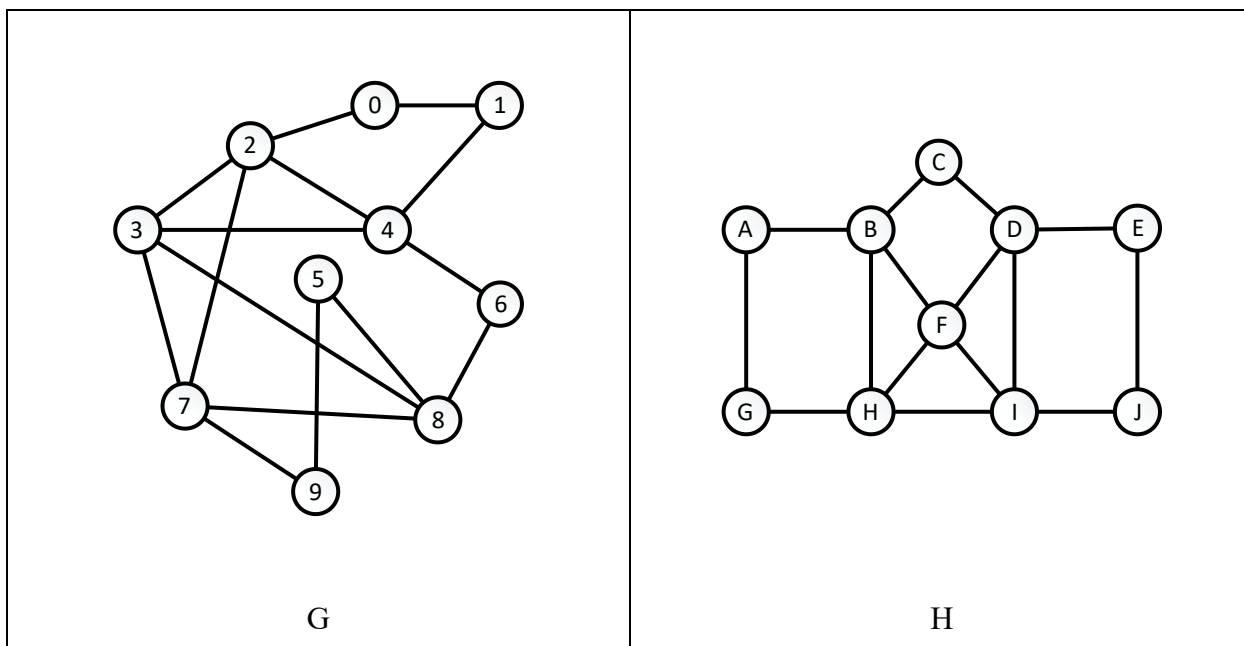

In the table below, give two **different** isomorphisms from G to H. You only need to specify the bijections between the vertices, i.e. from $V(G)$ to $V(H)$. The second row in the table describes the image of $V(G)$ for the first isomorphism, and the third row describes the image of $V(G)$ for the second isomorphism.

From $V(G)$:	0	1	2	3	4	5	6	7	8	9
To $V(H)$:										
To $V(H)$:										

PART B – SEQUENCES, RECURRENCE RELATIONS – 10 MARKS

Given the sequence a_n defined with the recurrence relation:

$$a_0 = 1$$

$$a_k = 3a_{k-1} + 7k \text{ for } k \geq 1$$

1. Terms of the Sequence (5 marks)

Calculate a_1, a_2, a_3, a_4, a_5

Keep your intermediate answers as you will need them in the next question.

2. Iteration (5 marks)

Guess a concise formula for a_n that uses the sum (Σ) and/or product (Π) notation.

PART C – INDUCTION – 15 MARKS

Given the sequence b_n defined recursively as:

$$b_0 = 1, b_1 = 4$$

$$b_k = 2b_{k-1} - b_{k-2} \text{ for } k \geq 2$$

You will now prove by **strong induction** that a solution to this sequence is $b_n = 1+3n$.

No other method is acceptable.

Be sure to lay out your proof clearly and correctly and to justify every step.

1. Problem Statement (2 marks)

The conjecture that you are proving, is expressed symbolically in the form $\forall n \in D, P(n)$.

a) (1 mark) What is the set D ?

b) (1 mark) What is the predicate function $P(n)$?

2. Base Cases (4 marks) Prove your base cases here:

3. Inductive step setup (3.5 marks)

c) (2 marks) State the assumption in the inductive step and identify the inductive hypothesis.

d) (1.5 marks) State what you will be proving in the inductive step.

4. Remainder of Inductive step (5.5 marks).

Finish your proof here. Be sure to justify every step, particularly why the recursive definition can be applied and where the inductive hypothesis is applied.

THIS PAGE IS INTENTIONALLY LEFT BLANK AND CAN BE USED FOR ROUGH WORK OR TO CONTINUE ANSWERING AN EARLIER QUESTION.

WORK ON THIS PAGE WILL ONLY BE GRADED IF SPECIFICALLY REQUESTED ON ONE OF PAGES 2 TO 7.

THIS PAGE IS INTENTIONALLY LEFT BLANK AND CAN BE USED FOR ROUGH WORK OR TO CONTINUE ANSWERING AN EARLIER QUESTION.

WORK ON THIS PAGE WILL ONLY BE GRADED IF SPECIFICALLY REQUESTED ON ONE OF PAGES 2 TO 7.

THIS PAGE IS INTENTIONALLY LEFT BLANK AND CAN BE USED FOR ROUGH WORK OR TO CONTINUE ANSWERING AN EARLIER QUESTION.

WORK ON THIS PAGE WILL ONLY BE GRADED IF SPECIFICALLY REQUESTED ON ONE OF PAGES 2 TO 7.